

FRONT VIEW - AP47627

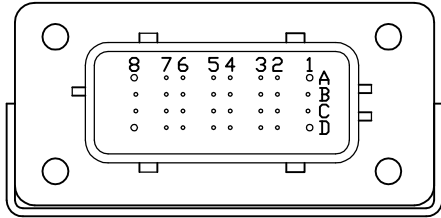

- PIN
- A1. BLK(W8601) - PUMP REQUEST
 - A2. YELLOW - CAN HIGH
 - A3. N/C
 - A4. N/C
 - A5. BLK(W2000) - RIGHT FRONT JACK WARNING SWITCH
 - A6. BLK(W2200) - RIGHT FRONT JACK PRESSURE SWITCH
 - A7. BLK(W3200) - RIGHT REAR JACK PRESSURE SWITCH
 - A8. BLK(W8101) - 50 LB. PRESSURE SWITCH
 - B1. RED(W6800) - TOUCH PANEL POWER
 - B2. GREEN - CAN LOW
 - B3. WHT(W6230) - TOUCH PANEL GROUND
 - B4. N/C
 - B5. BLK(W3000) - RIGHT REAR JACK WARNING SWITCH
 - B6. BLK(W4200) - LEFT REAR JACK PRESSURE SWITCH
 - B7. N/C
 - B8. BLK(W8100) - 3000 LB. PRESSURE SWITCH
 - C1. RED(W6121) - LEVEL SENSOR POWER
 - C2. CAN SHIELD
 - C3. WHT(W6231) - LEVEL SENSOR GROUND
 - C4. BLK(W0400) - REAR SENSE
 - C5. BLK(W4000) - LEFT REAR WARNING SWITCH
 - C6. N/C
 - C7. N/C
 - C8. BLK(W0300) - RIGHT SIDE SENSE
 - D1. RED(W6120) - ACCESSORY
 - D2. WHT(W6235) - WARNING SWITCH GROUND
 - D3. N/C
 - D4. BLK(W1000) - LEFT FRONT JACK WARNING SWITCH
 - D5. BLK(W1200) - LEFT FRONT PRESSURE SWITCH
 - D6. BLK(W0100) - LEFT SIDE SENSE
 - D7. BLK(W0200) - FRONT SENSE
 - D8. BLK(W9000) - PARK BRAKE

NOTE: WIRE NUMBERS ON THIS SHEET ARE REFERENCED TO HARNESS PLUGS.

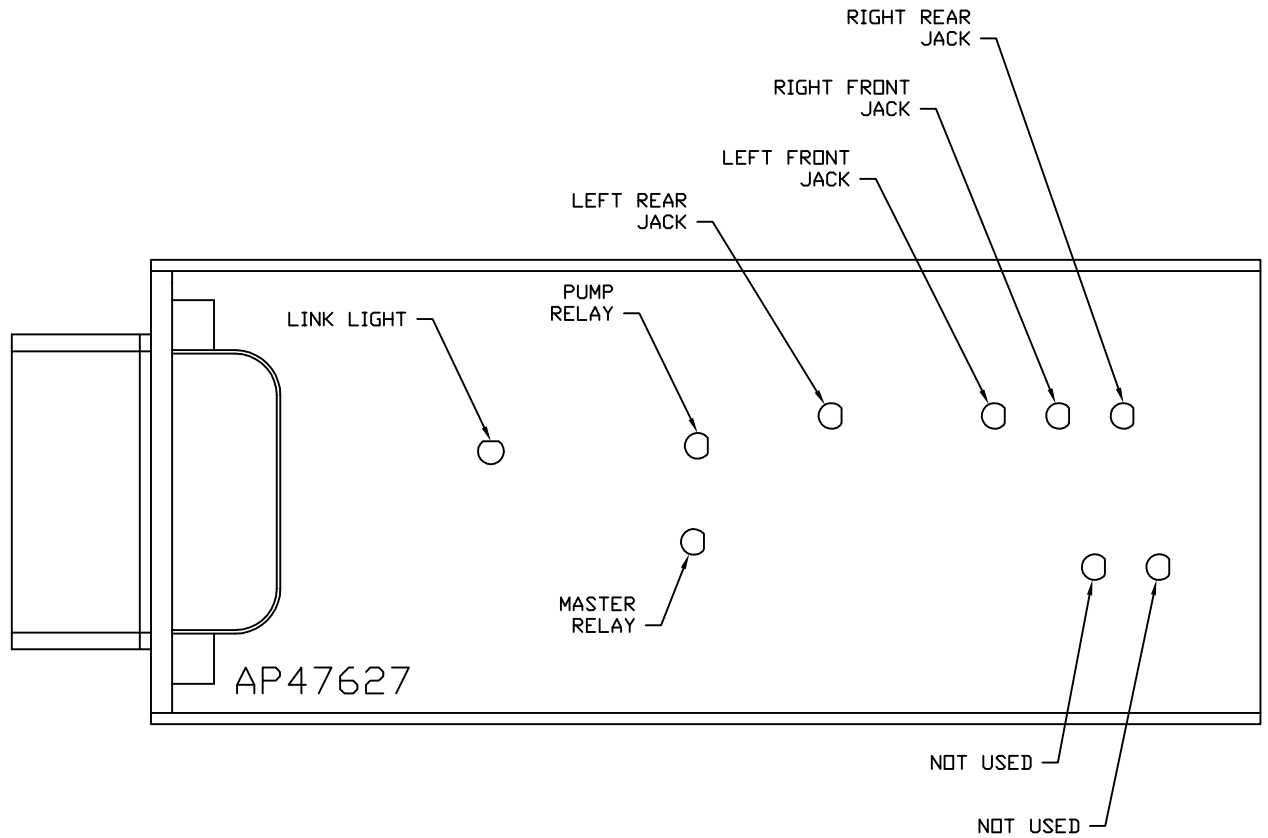

NOTE: INSTALLATION MUST CONFORM TO GOOD SHOP PRACTICES, SAE STANDARDS, RVIA STANDARDS, AND OTHER APPLICABLE STANDARDS.

		HWH		I-80 EXIT 267 SOUTH RT 1 MOSCOW, IOWA 52760	
		SCALE 1:3	DATE 10DEC10	DRAWN BY .	
		SYSTEM SCHEMATIC ELEC			
NO.	DATE	REVISION			
THE INFORMATION DISCLOSED ON THIS DRAWING IS CONFIDENTIAL AND MUST NOT BE DISCLOSED OR USED IN ANY MANNER WHICH WILL BE DETRIMENTAL TO THE HWH CORPORATION			DRAWING NUMBER MP90561 A/D		

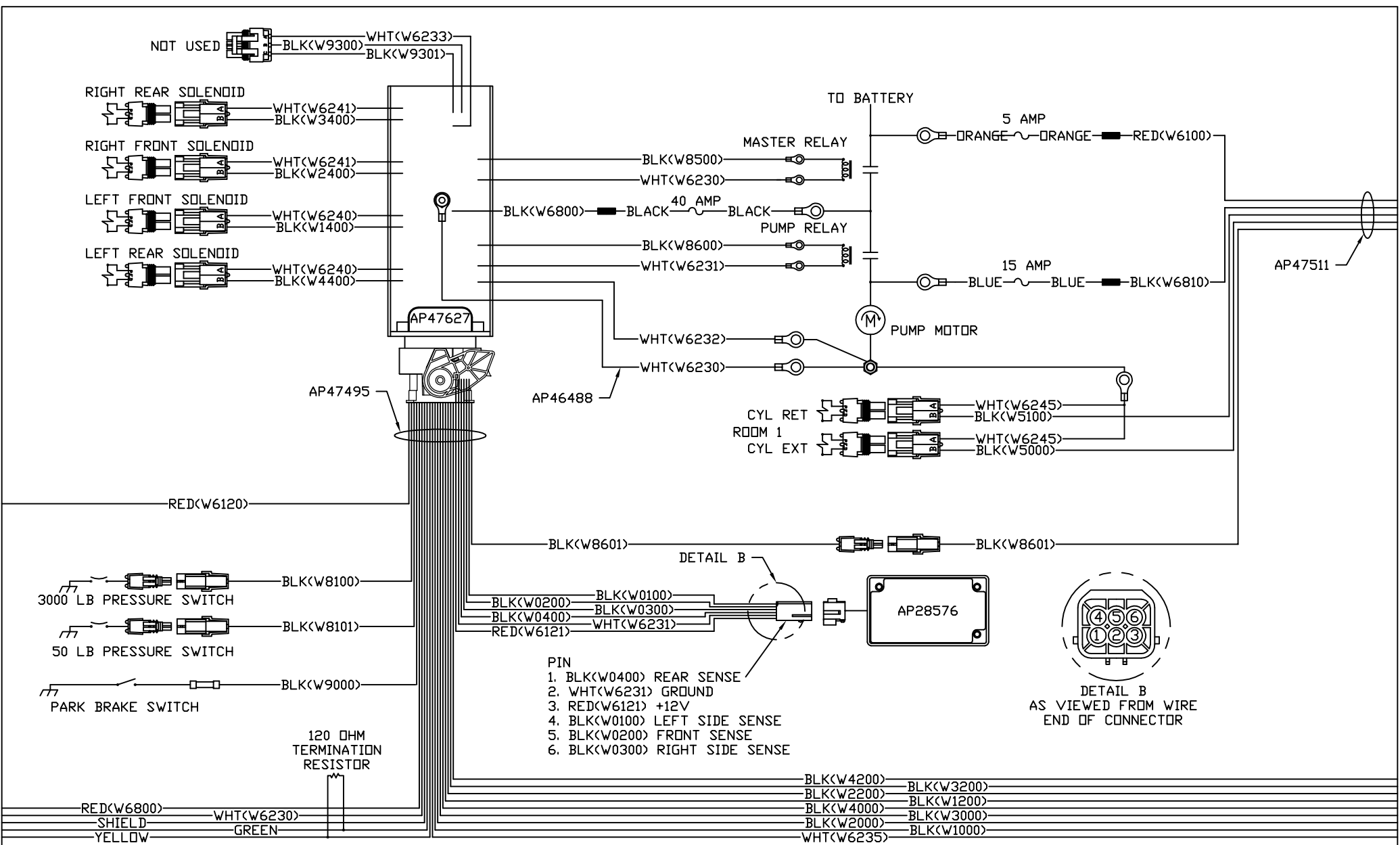

NOTE: INSTALLATION MUST CONFORM TO GOOD SHOP PRACTICES, SAE STANDARDS, RVIA STANDARDS, AND OTHER APPLICABLE STANDARDS.

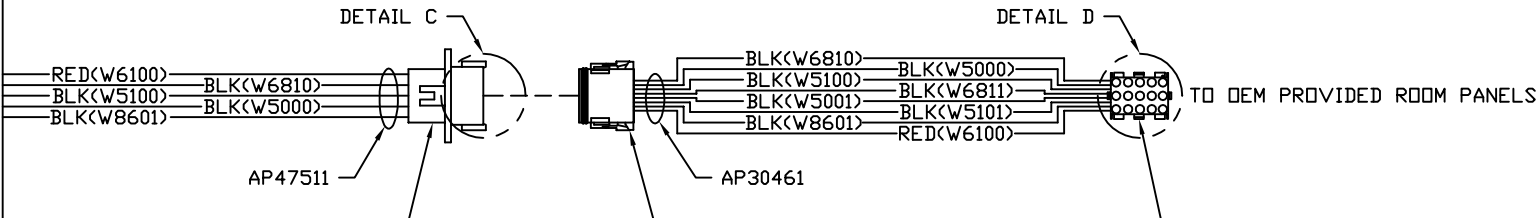
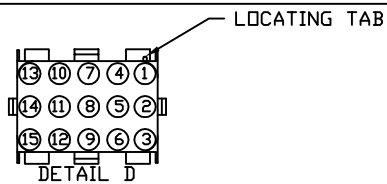
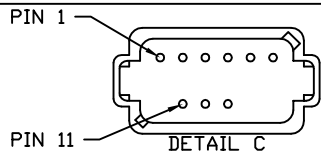

- PIN
1. BLK<W6810> SW. BATT ROOM 1
 2. BLK<W5000> CYL. EXTEND ROOM 1
 3. BLK<W5100> CYL. RETRACT ROOM 1
 4. N/C
 5. N/C
 6. N/C
 7. N/C
 8. N/C
 9. N/C (KEY PIN)
 10. BLK<W8601> PUMP REQUEST
 11. RED<W6100> BATTERY
 12. N/C

- PIN
1. BLK<W6810> ROOM 1 SW. BATT
 2. BLK<W5000> ROOM 1 EXTEND
 3. BLK<W5100> ROOM 1 RETRACT
 4. BLK<W6811> NOT USED
 5. BLK<W5001> NOT USED
 6. BLK<W5101> NOT USED
 7. N/C
 8. N/C (KEY PIN)
 9. N/C
 10. BLK<W8601> PUMP REQUEST
 11. RED<W6100> BATTERY
 12. N/C (KEY PIN)

- PIN
1. BLK<W5000> ROOM 1 EXTEND
 2. BLK<W5100> ROOM 1 RETRACT
 3. BLK<W6810> ROOM 1 SW. BATT.
 4. BLK<W5001> NOT USED
 5. BLK<W5101> NOT USED
 6. BLK<W6811> NOT USED
 7. N/C
 8. N/C
 9. N/C
 10. N/C
 11. N/C
 12. N/C
 13. BLK<W8601> PUMP REQUEST
 14. RED<W6100> BATTERY
 15. N/C

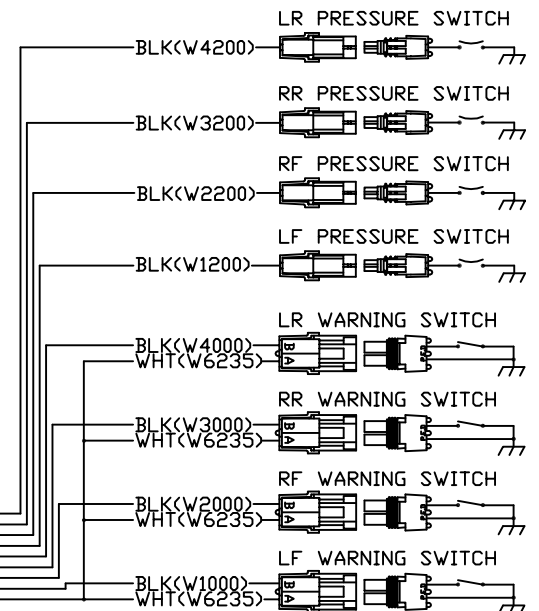

NOTE: INSTALLATION MUST CONFORM TO GOOD SHOP PRACTICES, SAE STANDARDS, RVIA STANDARDS, AND OTHER APPLICABLE STANDARDS.

AP47495

MP90561 D
10DEC10