

FRONT VIEW - AP48445

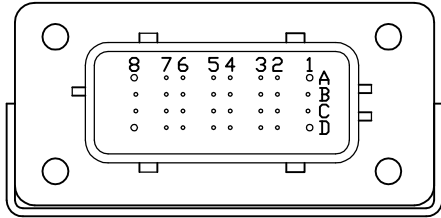

- PIN
- A1. RED(W6120) - ACCESSORY
 - A2. YELLOW - CAN HIGH
 - A3. N/C
 - A4. N/C
 - A5. N/C
 - A6. BLK(W2210) - RIGHT FRONT AIR PRESSURE SWITCH
 - A7. BLK(W7521) - TAG DUMP CONTROL
 - A8. BLACK - NOT USED
 - B1. RED(W6122) - POWER OUT
 - B2. GREEN - CAN LOW
 - B3. N/C
 - B4. N/C
 - B5. N/C
 - B6. BLK(W7522) - TAG DUMP REVERSE ENABLE
 - B7. N/C
 - B8. N/C
 - C1. RED(W6121) - +12V TO TAG SWITCH
 - C2. CAN SHIELD
 - C3. N/C
 - C4. N/C
 - C5. N/C
 - C6. N/C
 - C7. N/C
 - C8. N/C
 - D1. RED(W6102) - SW. BATTERY
 - D2. WHT(W6232) - PRESSURE SWITCH GROUND
 - D3. WHT(W6230) - TOUCH PANEL AND BRIDGE GROUND
 - D4. N/C
 - D5. BLK(W1210) - LEFT FRONT AIR PRESSURE SWITCH
 - D6. N/C
 - D7. N/C
 - D8. BLACK - NOT USED

NOTE: WIRE NUMBERS ON THIS SHEET ARE REFERENCED TO HARNESS PLUGS.

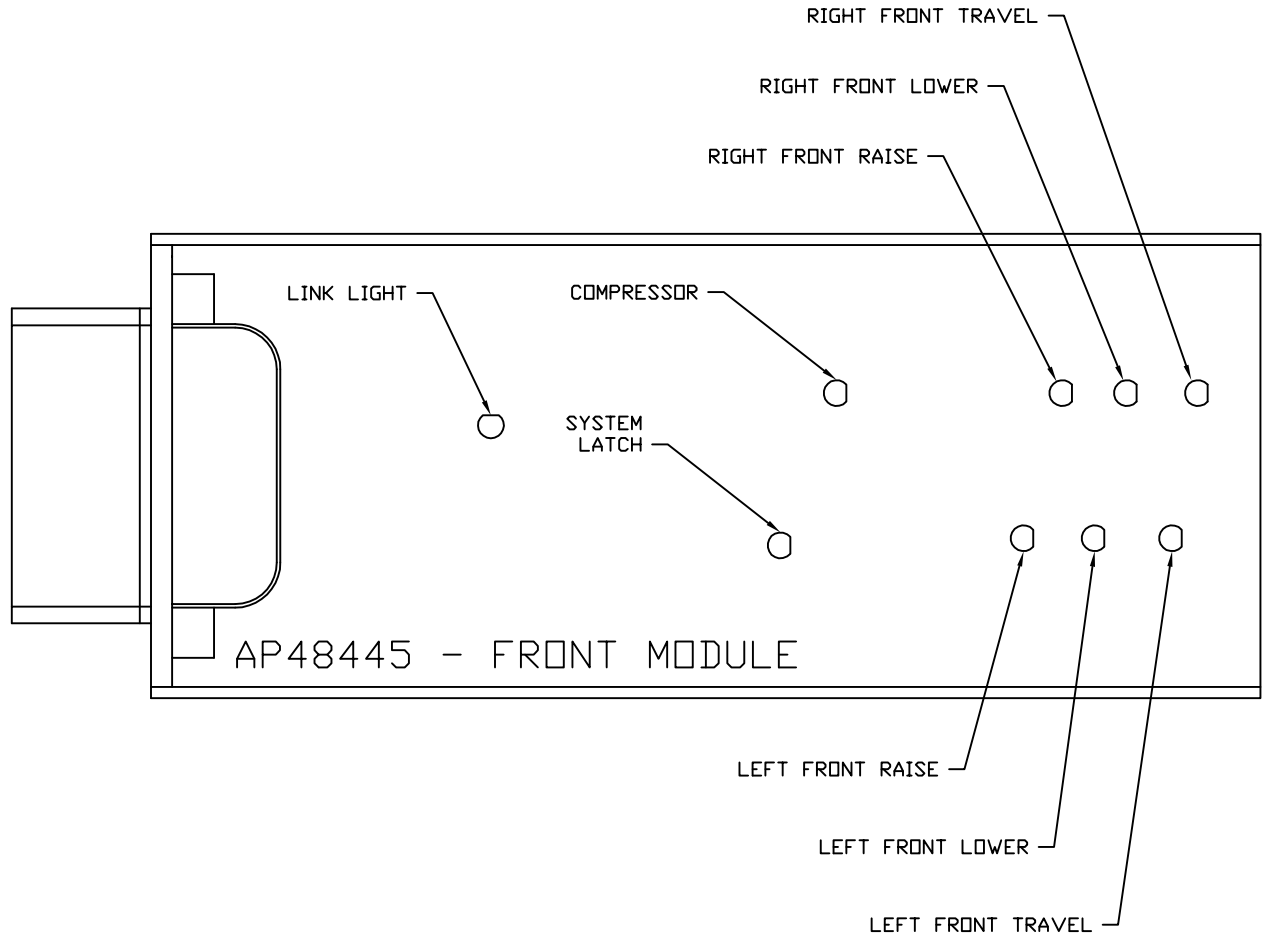

5	08JUN17	CORRECTED LABEL
5	21DEC16	ADDED 'AIR' AND 'JACK'
3	31MAR16	WAS AP33330, AP53748
3	14SEP15	RSV'D WIRE NUMBER
2	22JUL15	RSV'D TAG & RESET SW.
1	01JUL15	RSV'D TAG SW. LOCATION
NO.	DATE	REVISION

HWH		I-80 EXIT 267 SOUTH	
		RT 1 MOSCOW, IOWA 52760	
SCALE 1:3	DATE 08JUN15	DRAWN BY .	
SYSTEM SCHEMATIC ELEC			

NOTE: INSTALLATION MUST CONFORM TO GOOD SHOP PRACTICES, SAE STANDARDS, RVIA STANDARDS, AND OTHER APPLICABLE STANDARDS.

THE INFORMATION DISCLOSED ON THIS DRAWING IS CONFIDENTIAL AND MUST NOT BE DISCLOSED OR USED IN ANY MANNER WHICH WILL BE DETRIMENTAL TO THE HWH CORPORATION

DRAWING NUMBER
MP91148 A/J

FRONT VIEW - AP45494

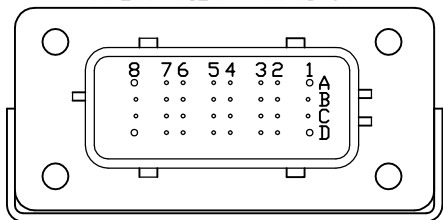

PIN

- A1. BLACK - NOT USED
- A2. YELLOW - CAN HIGH
- A3. N/C
- A4. N/C
- A5. BLK(W2000) - RIGHT FRONT JACK WARNING SWITCH
- A6. BLK(W2200) - RIGHT FRONT JACK PRESSURE SWITCH
- A7. BLK(W3200) - RIGHT REAR JACK PRESSURE SWITCH
- A8. BLK(W8101) - 50 LB. PRESSURE SWITCH
- B1. N/C
- B2. GREEN - CAN LOW
- B3. N/C
- B4. N/C
- B5. BLK(W3000) - RIGHT REAR JACK WARNING SWITCH
- B6. BLK(W4200) - LEFT REAR JACK PRESSURE SWITCH
- B7. N/C
- B8. BLK(W8100) - 3000 LB. PRESSURE SWITCH
- C1. RED(W6112) - LEVEL SENSOR POWER
- C2. CAN SHIELD
- C3. WHT(W6231) - LEVEL SENSOR GROUND
- C4. BLK(W0400) - REAR SENSE
- C5. BLK(W4000) - LEFT REAR JACK WARNING SWITCH
- C6. N/C
- C7. N/C
- C8. BLK(W0300) - RIGHT SIDE SENSE
- D1. RED(W6121) - POWER
- D2. WHT(W6235) - WARNING SWITCH GROUND
- D3. N/C
- D4. BLK(W1000) - LEFT FRONT JACK WARNING SWITCH
- D5. BLK(W1200) - LEFT FRONT JACK PRESSURE SWITCH
- D6. BLK(W0100) - LEFT SIDE SENSE
- D7. BLK(W0200) - FRONT SENSE
- D8. BLK(W9000) - PARK BRAKE

NOTE: WIRE NUMBERS ON THIS SHEET ARE REFERENCED TO HARNESS PLUGS.

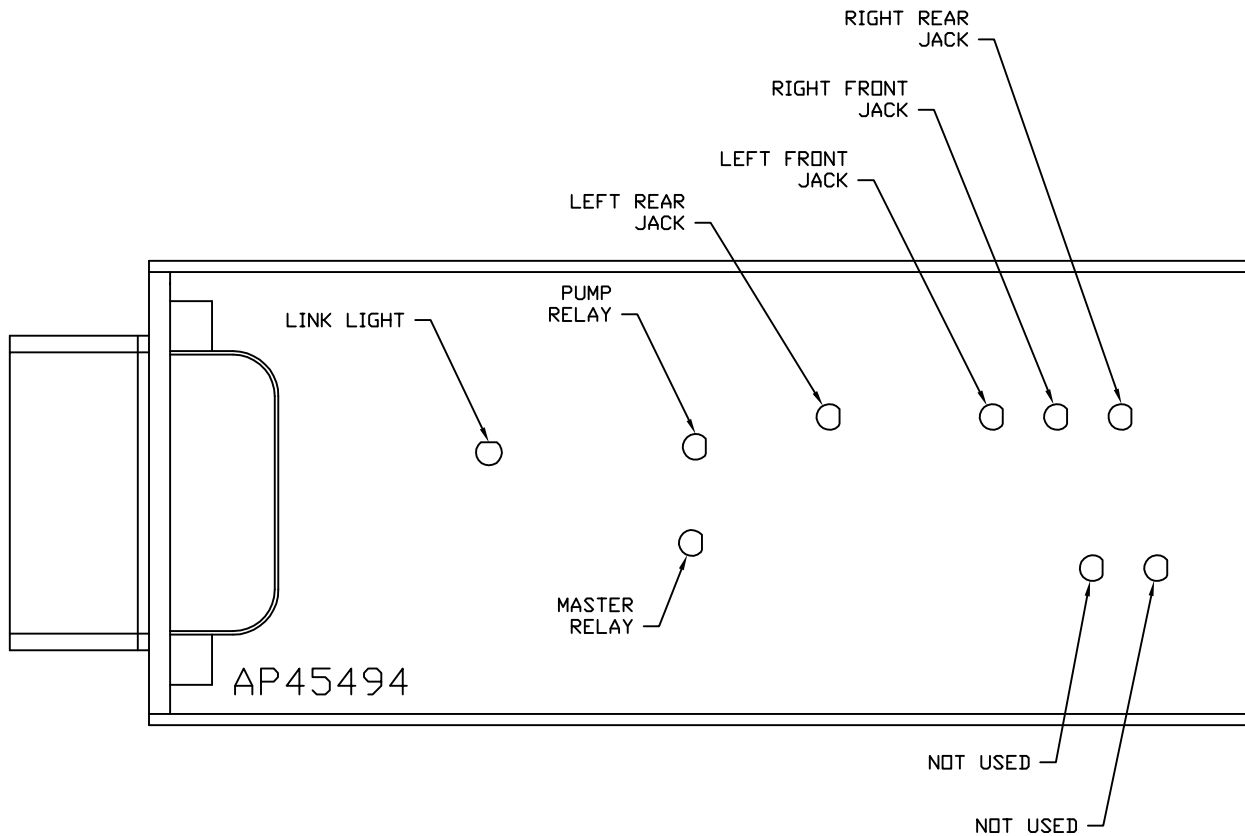

NOTE: INSTALLATION MUST CONFORM TO GOOD SHOP PRACTICES, SAE STANDARDS, RVIA STANDARDS, AND OTHER APPLICABLE STANDARDS.

FRONT VIEW - AP48446

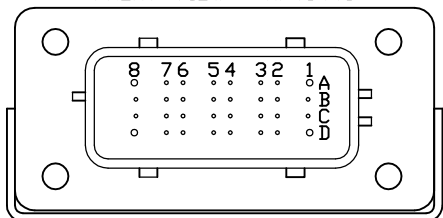

- PIN
- A1. BLACK - NOT USED
 - A2. YELLOW - CAN HIGH
 - A3. N/C
 - A4. N/C
 - A5. N/C
 - A6. BLK(W3210) - RIGHT REAR AIR PRESSURE SWITCH
 - A7. N/C
 - A8. BLACK - NOT USED
 - B1. N/C
 - B2. GREEN - CAN LOW
 - B3. N/C
 - B4. N/C
 - B5. N/C
 - B6. N/C
 - B7. N/C
 - B8. BLK(W3215) - SYSTEM AIR PRESSURE SWITCH
 - C1. N/C
 - C2. CAN SHIELD
 - C3. N/C
 - C4. N/C
 - C5. N/C
 - C6. N/C
 - C7. N/C
 - C8. N/C
 - D1. RED(W6122) - POWER
 - D2. WHT(W6233) - PRESSURE SWITCH GROUND
 - D3. N/C
 - D4. N/C
 - D5. BLK(W4210) - LEFT REAR AIR PRESSURE SWITCH
 - D6. N/C
 - D7. N/C
 - D8. BLACK - NOT USED

NOTE: WIRE NUMBERS ON THIS SHEET ARE REFERENCED TO HARNESS PLUGS.

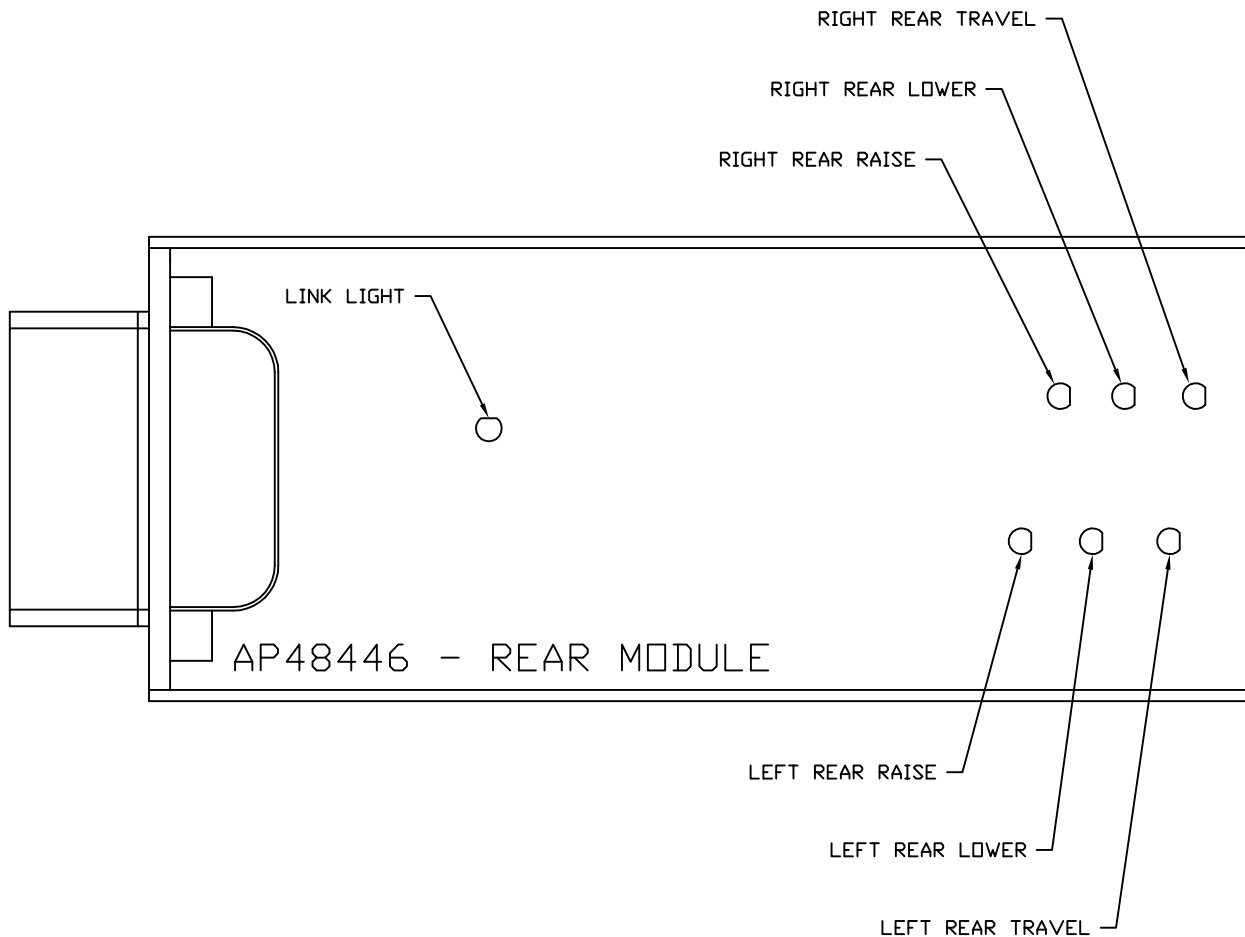

NOTE: INSTALLATION MUST CONFORM TO GOOD SHOP PRACTICES, SAE STANDARDS, RVIA STANDARDS, AND OTHER APPLICABLE STANDARDS.

FRONT VIEW - AP52365

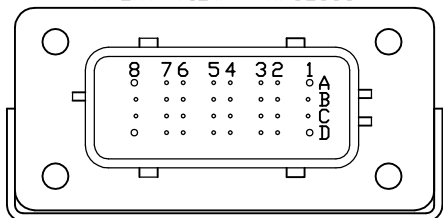

- PIN
- A1. BLACK - NOT USED
 - A2. YELLOW - CAN HIGH
 - A3. N/C
 - A4. N/C
 - A5. N/C
 - A6. BLK(W3211) - RIGHT TAG AIR PRESSURE SWITCH
 - A7. N/C
 - A8. BLACK - NOT USED
 - B1. N/C
 - B2. GREEN - CAN LOW
 - B3. N/C
 - B4. N/C
 - B5. N/C
 - B6. N/C
 - B7. N/C
 - B8. N/C
 - C1. N/C
 - C2. CAN SHIELD
 - C3. N/C
 - C4. N/C
 - C5. N/C
 - C6. N/C
 - C7. N/C
 - C8. N/C
 - D1. RED(W6122) - POWER
 - D2. WHT(W6234) - PRESSURE SWITCH GROUND
 - D3. N/C
 - D4. N/C
 - D5. BLK(W4211) - LEFT TAG AIR PRESSURE SWITCH
 - D6. N/C
 - D7. N/C
 - D8. BLACK - NOT USED

NOTE: WIRE NUMBERS ON THIS SHEET ARE REFERENCED TO HARNESS PLUGS.

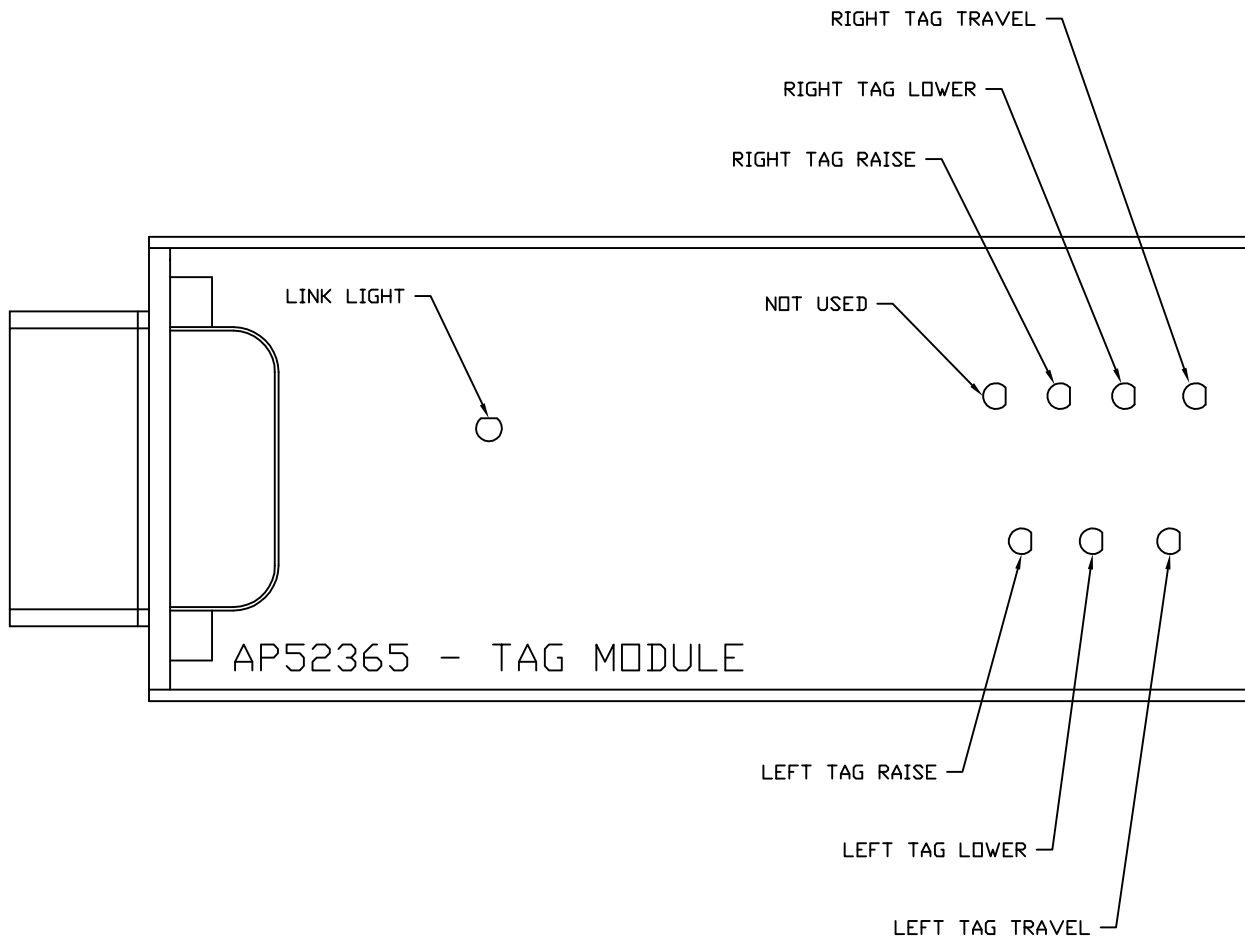

NOTE: INSTALLATION MUST CONFORM TO GOOD SHOP PRACTICES, SAE STANDARDS, RVIA STANDARDS, AND OTHER APPLICABLE STANDARDS.

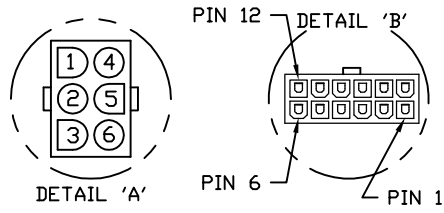

- PIN
- 1. N/C
 - 2. SWITCH COMMON (+12V)
 - 3. STORE
 - 4. SWITCH LED
 - 5. WARNING
 - 6. HYD. LEVEL

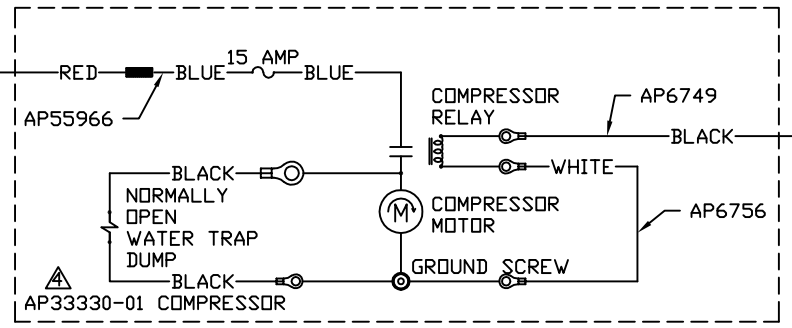
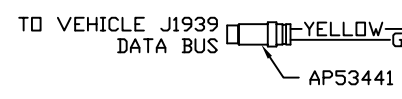
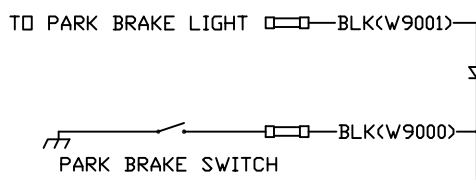
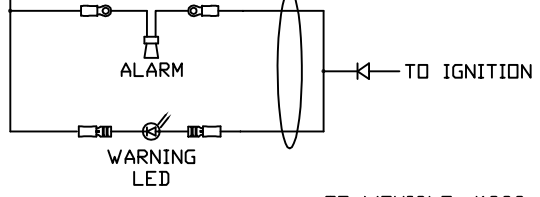
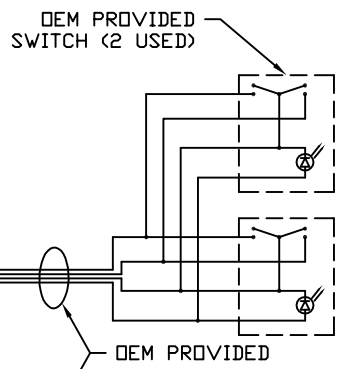
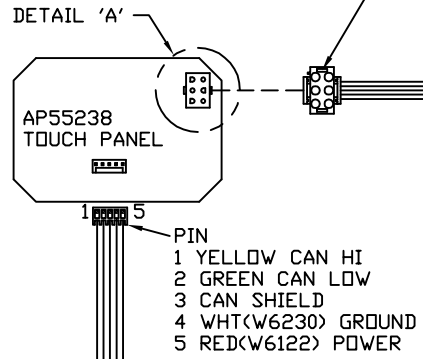

- PIN
- 1 WHT(W6230) GROUND
 - 2 - 4 N/C
 - 5 YELLOW (RV-C)
 - 6 GREEN (RV-C)
 - 7 RED(W6122) POWER
 - 8 - 10 N/C
 - 11 YELLOW (J1939)
 - 12 GREEN (J1939)

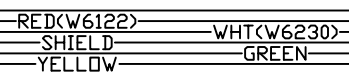
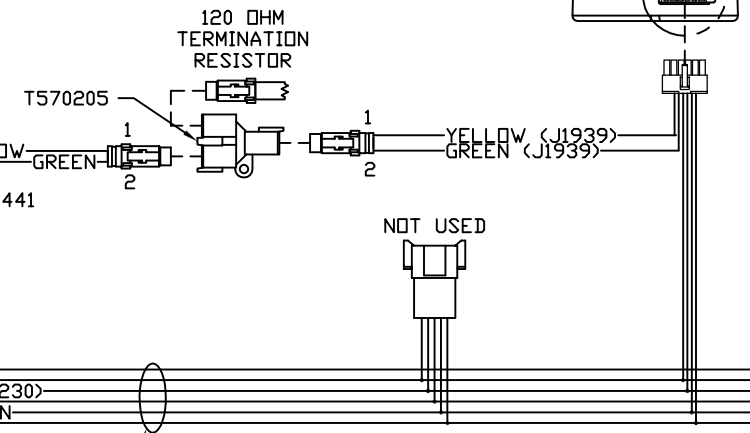
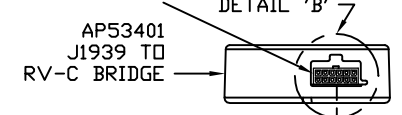

AP55389

NOTE: INSTALLATION MUST CONFORM TO GOOD SHOP PRACTICES, SAE STANDARDS, RVIA STANDARDS, AND OTHER APPLICABLE STANDARDS.

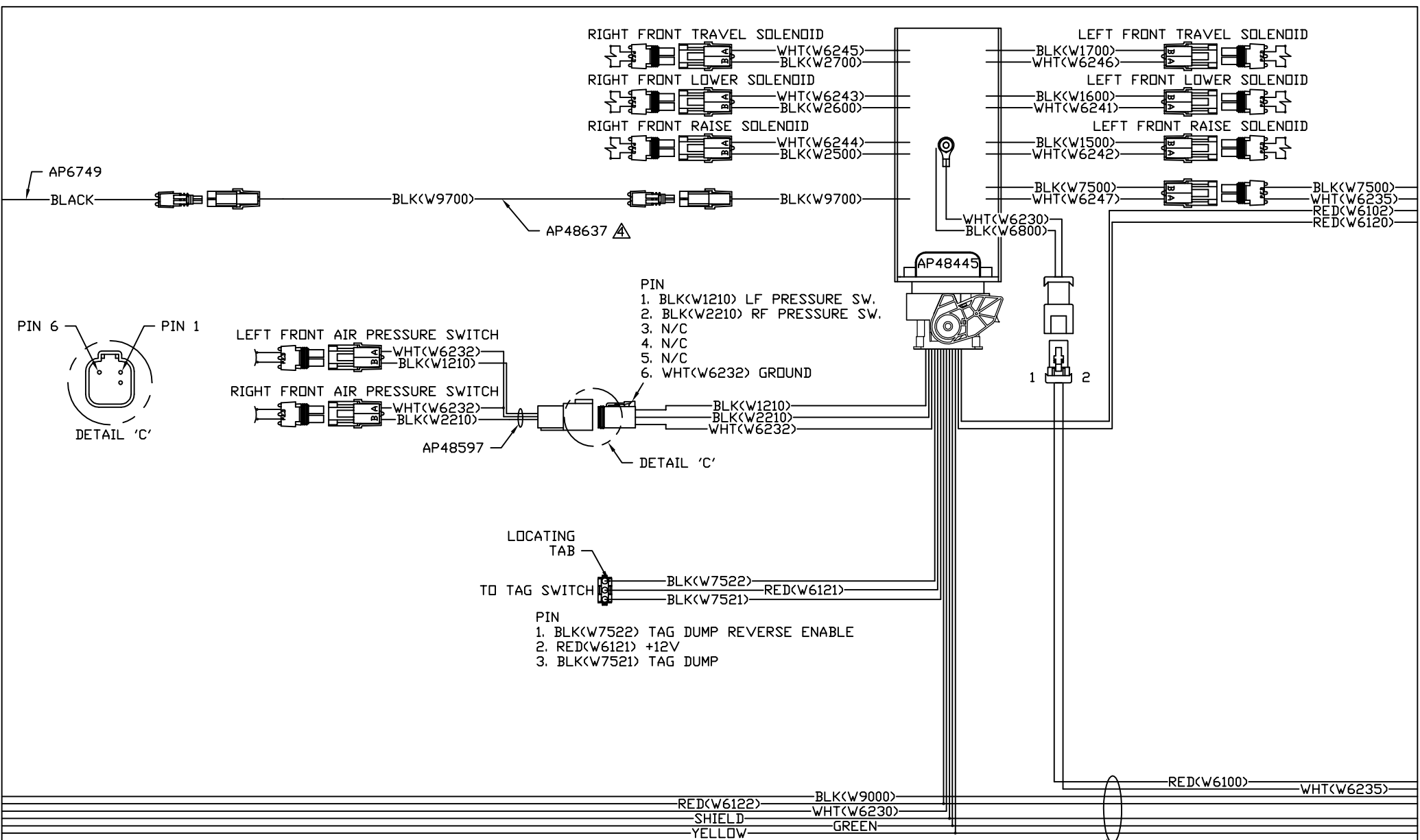

NOTE: INSTALLATION MUST CONFORM TO GOOD SHOP PRACTICES, SAE STANDARDS, RVIA STANDARDS, AND OTHER APPLICABLE STANDARDS.

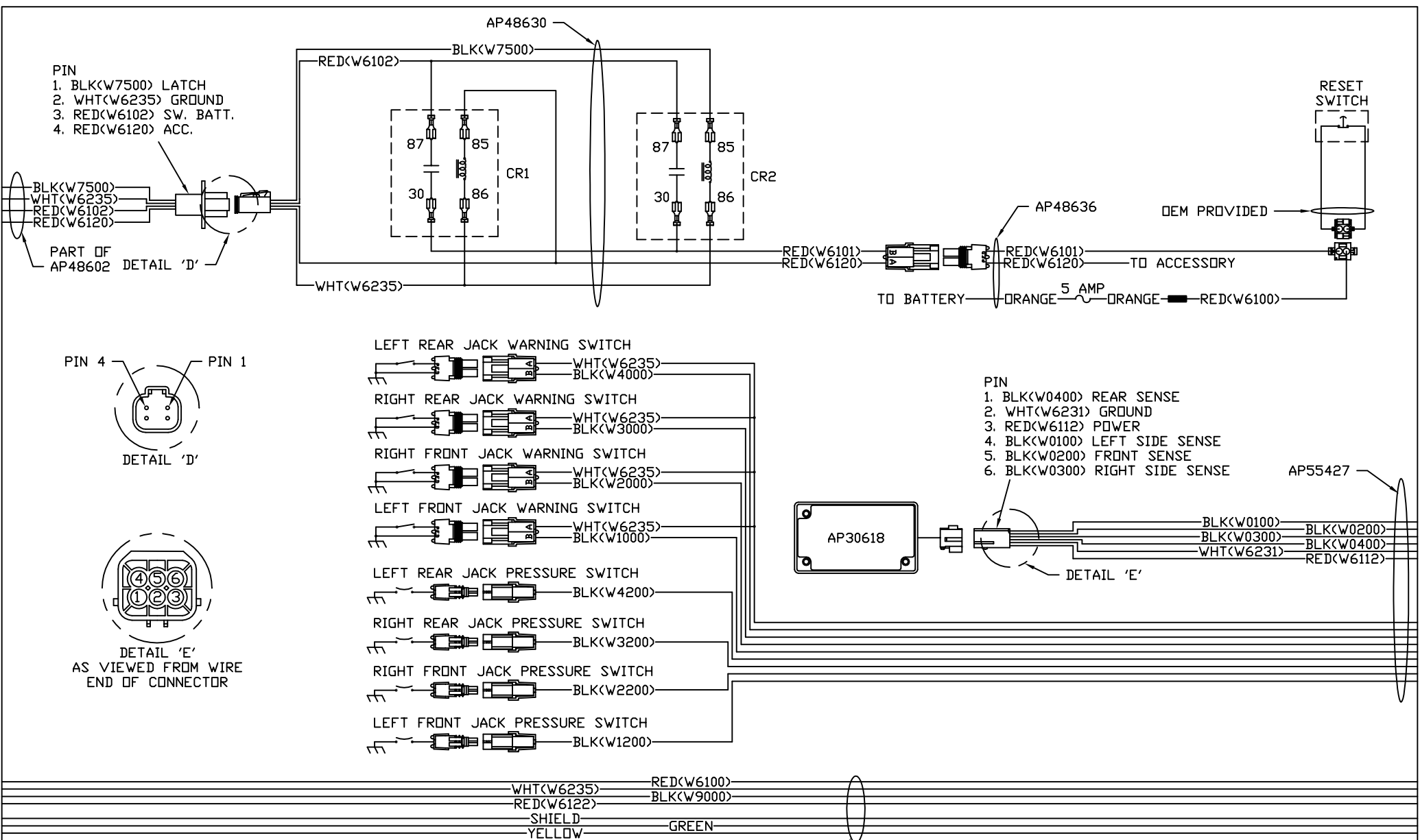

PIN
 1. BLK(W7500) LATCH
 2. WHT(W6235) GROUND
 3. RED(W6102) SW. BATT.
 4. RED(W6120) ACC.

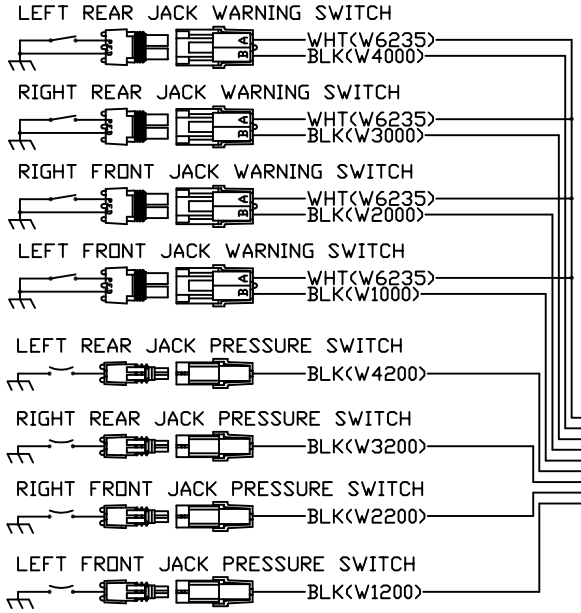
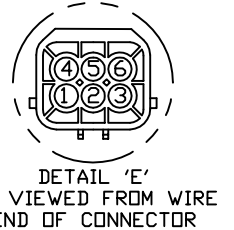
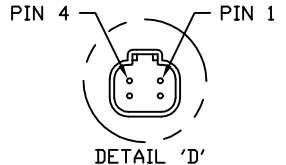
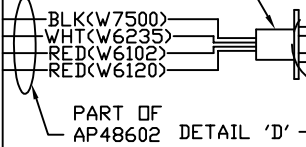

PIN
 1. BLK(W0400) REAR SENSE
 2. WHT(W6231) GROUND
 3. RED(W6112) POWER
 4. BLK(W0100) LEFT SIDE SENSE
 5. BLK(W0200) FRONT SENSE
 6. BLK(W0300) RIGHT SIDE SENSE

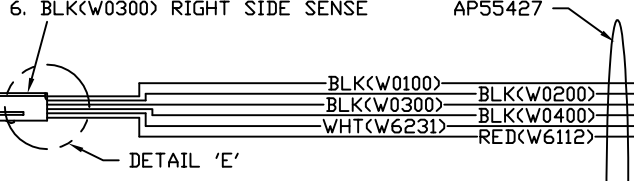

WHT(W6235)
 RED(W6122)
 SHIELD
 YELLOW
 RED(W6100)
 BLK(W9000)
 GREEN

NOTE: INSTALLATION MUST CONFORM TO GOOD SHOP PRACTICES, SAE STANDARDS, RVIA STANDARDS, AND OTHER APPLICABLE STANDARDS.

AP55389

MP91148 G
 21DEC16

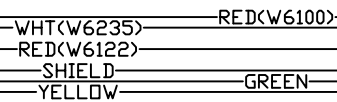
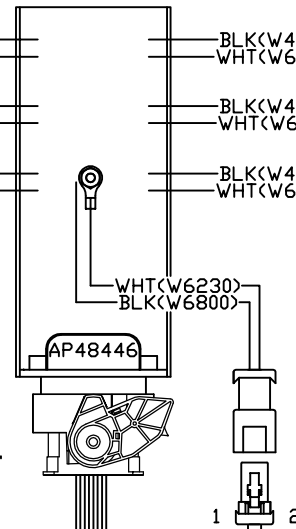
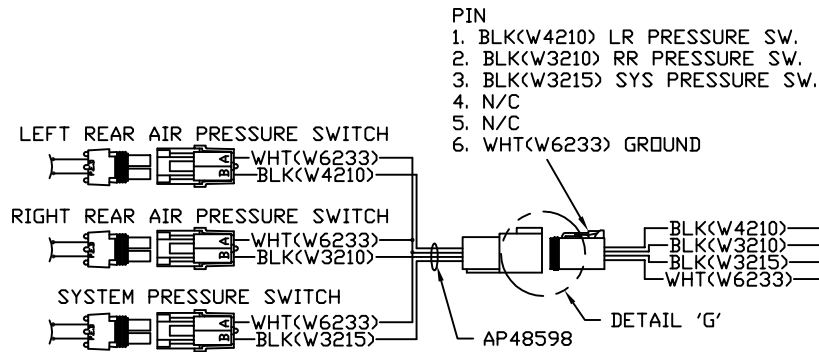
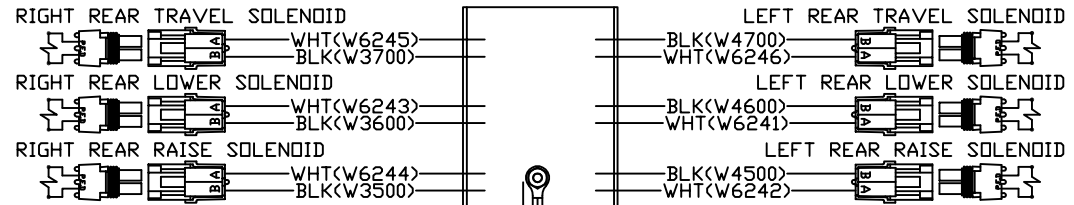
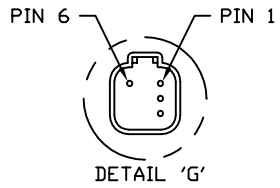

NOTE: INSTALLATION MUST CONFORM TO GOOD SHOP PRACTICES, SAE STANDARDS, RVIA STANDARDS, AND OTHER APPLICABLE STANDARDS.

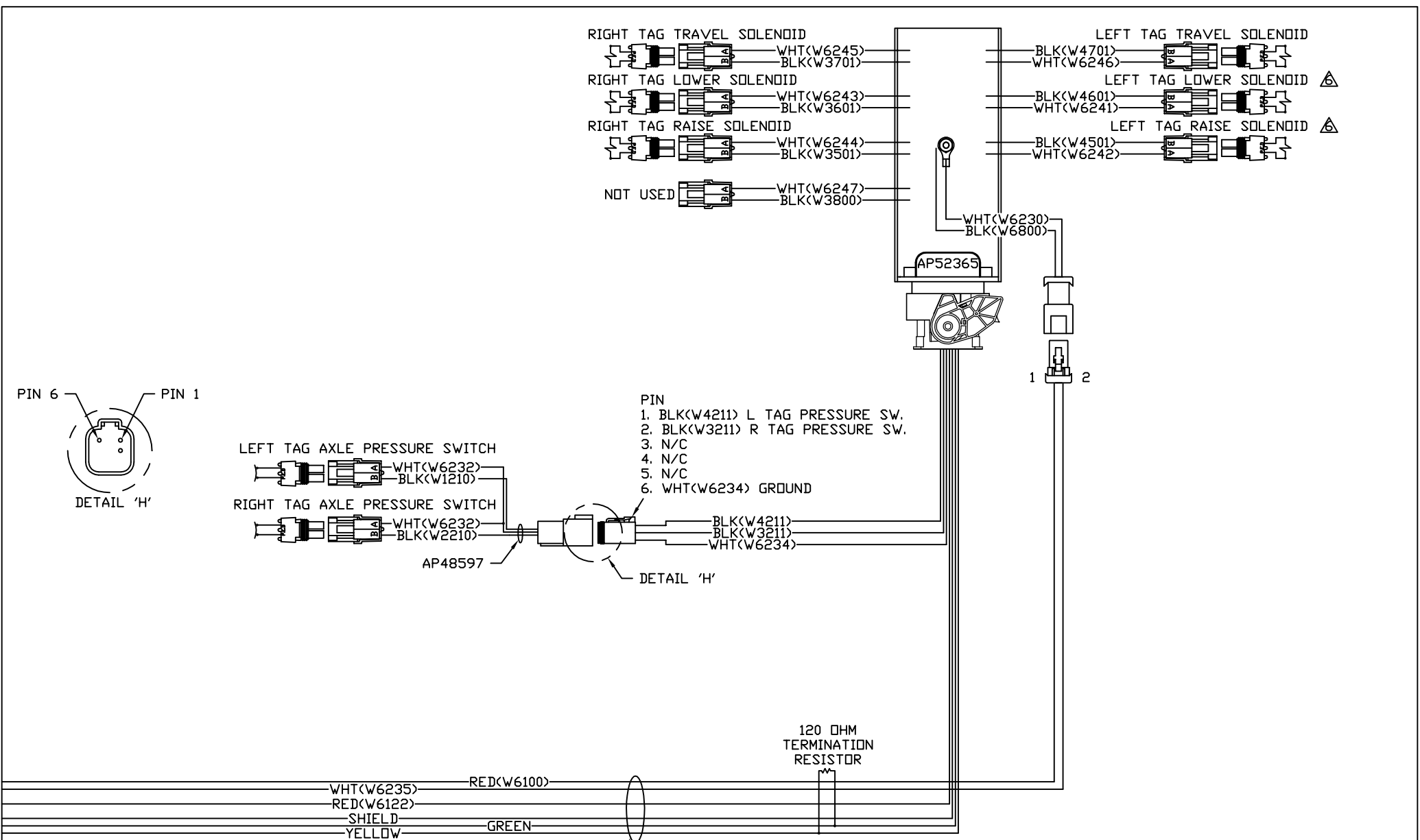

NOTE: INSTALLATION MUST CONFORM TO GOOD SHOP PRACTICES, SAE STANDARDS, RVIA STANDARDS, AND OTHER APPLICABLE STANDARDS.