

FRONT VIEW - AP58468

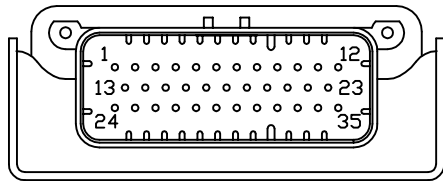

- PIN
1. BLK(W9000) - PARK BRAKE
 2. N/C
 3. BLK(W8101) - 50 LB. PRESSURE SWITCH
 4. BLK(W0100) - LEFT SIDE SENSE
 5. BLK(W0400) - REAR SENSE
 6. BLK(W3000) - RIGHT REAR JACK WARNING SWITCH
 7. BLK(W2200) - RIGHT FRONT JACK PRESSURE SWITCH
 8. N/C
 9. BLK(W8601) - PUMP REQUEST
 10. N/C
 11. WHT(W6235) - WARNING SWITCH GROUND
 12. N/C
 13. N/C
 14. N/C
 15. N/C
 16. BLK(W0300) - RIGHT SIDE SENSE
 17. BLK(W2000) - RIGHT FRONT JACK WARNING SWITCH
 18. BLK(W1200) - LEFT FRONT JACK PRESSURE SWITCH
 19. N/C
 20. WHT(W6230) - TOUCH PANEL GROUND
 21. CAN SHIELD
 22. YELLOW - CAN HIGH
 23. GREEN - CAN LOW
 24. N/C
 25. BLK(W4200) - LEFT REAR JACK PRESSURE SWITCH
 26. BLK(W8100) - 3000 LB. PRESSURE SWITCH
 27. BLK(W0200) - FRONT SENSE
 28. BLK(W1000) - LEFT FRONT JACK WARNING SWITCH
 29. BLK(W4000) - LEFT REAR JACK WARNING SWITCH
 30. BLK(W3200) - RIGHT REAR JACK PRESSURE SWITCH
 31. N/C
 32. WHT(W6231) - LEVEL SENSOR GROUND
 33. RED(W6121) - LEVEL SENSOR POWER
 34. RED(W6800) - TOUCH PANEL POWER
 35. RED(W6120) - ACCESSORY

NOTE: WIRE NUMBERS ON THIS SHEET ARE REFERENCED TO HARNESS PLUGS.

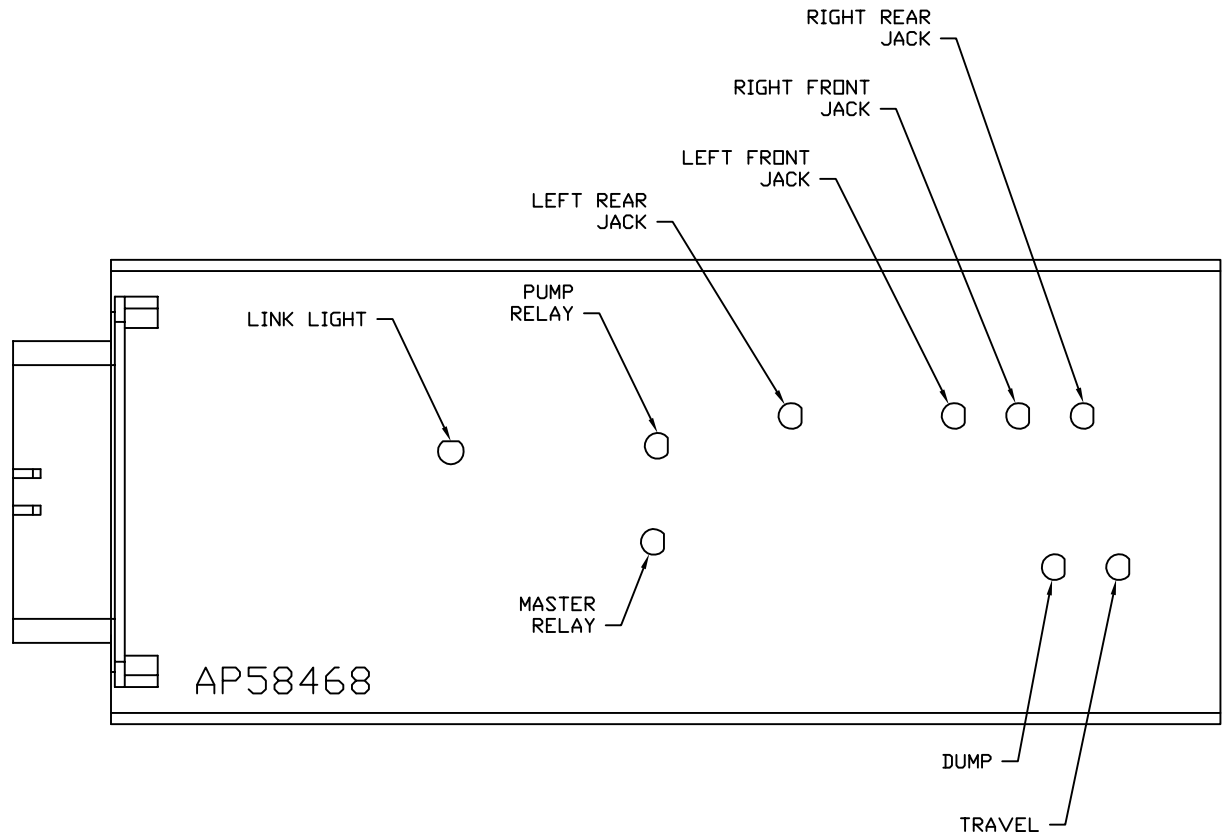

NOTE: INSTALLATION MUST CONFORM TO GOOD SHOP PRACTICES, SAE STANDARDS, RVIA STANDARDS, AND OTHER APPLICABLE STANDARDS.

		HWH		I-80 EXIT 267 SOUTH RT 1 MOSCOW, IOWA 52760	
		SCALE 1:3	DATE 13FEB18	DRAWN BY .	
▲	17APR18	WAS 15 AMP			
NO.	DATE	REVISION			
		SYSTEM SCHEMATIC ELEC			
THE INFORMATION DISCLOSED ON THIS DRAWING IS CONFIDENTIAL AND MUST NOT BE DISCLOSED OR USED IN ANY MANNER WHICH WILL BE DETRIMENTAL TO THE HWH CORPORATION				DRAWING NUMBER MP91361 A/D	

NOTE: AP46382 TOUCH PANEL AND AP47709 CHIME KIT WHICH INCLUDES AP47711 AND AP47978 ARE ORDERED SEPARATELY FROM HWH CORP.

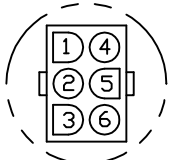

DETAIL A

- PIN
1. N/C
 2. N/C
 3. N/C
 4. N/C
 5. BLK(W7699) WARNING LED/CHIME CONTROL
 6. N/C

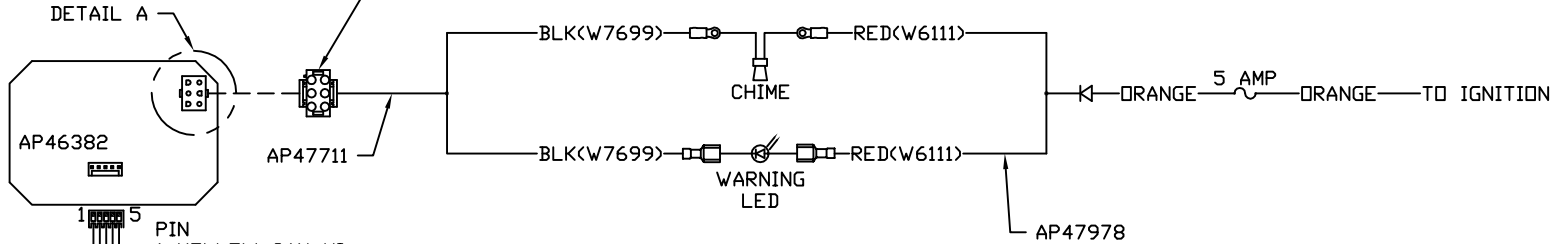

- PIN
1. YELLOW CAN HI
 2. GREEN CAN LOW
 3. CAN SHIELD
 4. WHT(W6230) GROUND
 5. RED(W6800) POWER

120 OHM
TERMINATION
RESISTOR

- RED(W6800)
SHIELD
YELLOW
- WHT(W6230)
GREEN

TO OEM PROVIDED
PILOT DUMP CONNECTION

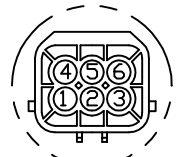
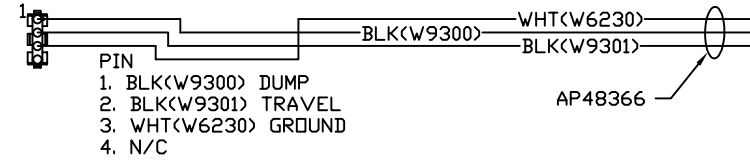

DETAIL B
AS VIEWED FROM WIRE
END OF CONNECTOR

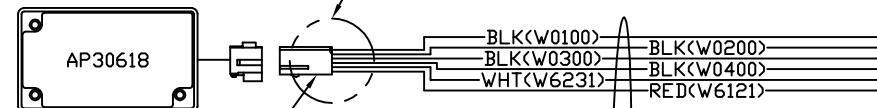

NOTE: INSTALLATION MUST CONFORM TO GOOD SHOP PRACTICES, SAE STANDARDS, RVIA STANDARDS, AND OTHER APPLICABLE STANDARDS.

MP91361 B
13FEB18

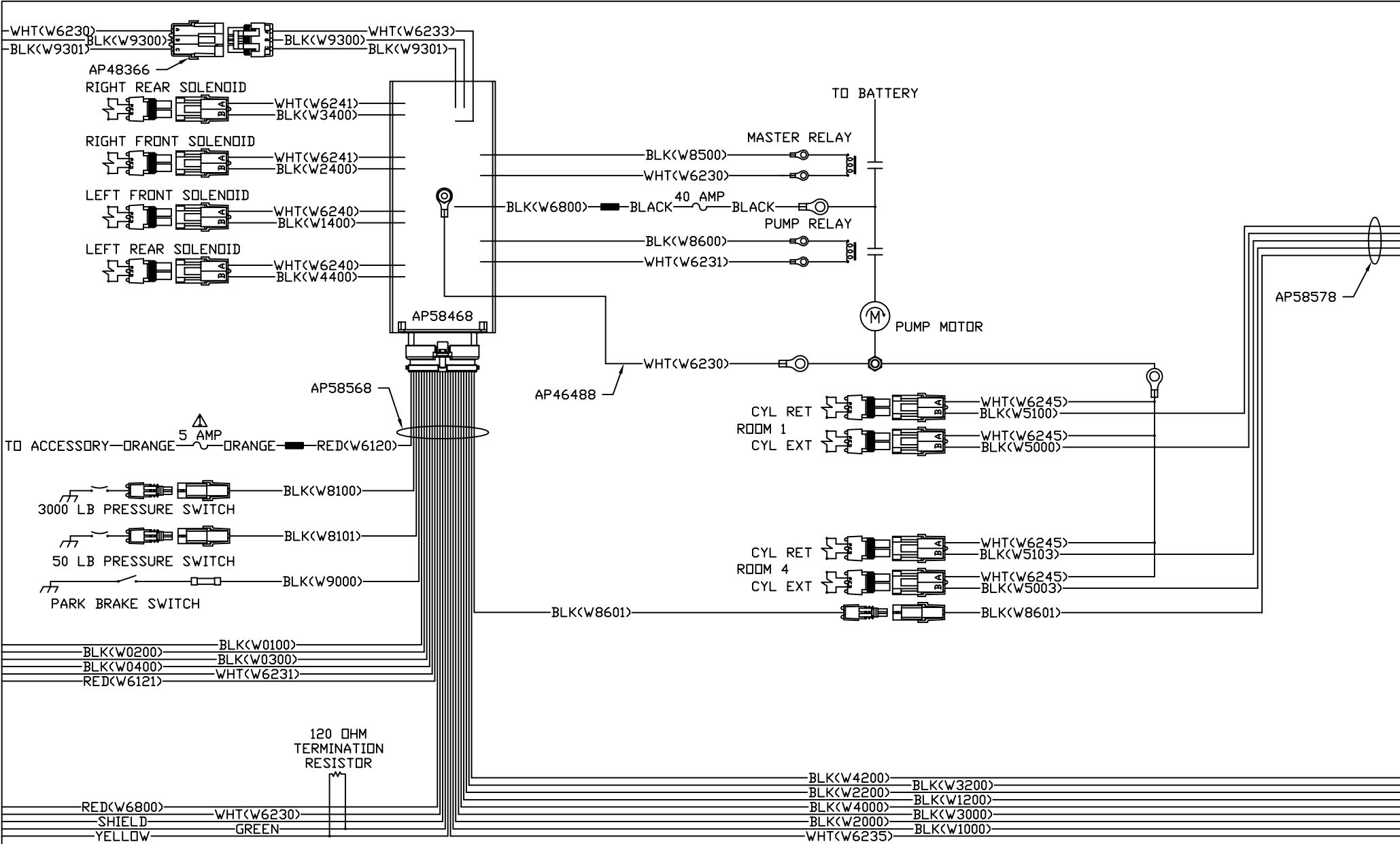

NOTE: INSTALLATION MUST CONFORM TO GOOD SHOP PRACTICES, SAE STANDARDS, RVIA STANDARDS, AND OTHER APPLICABLE STANDARDS.

LOCATING PIN

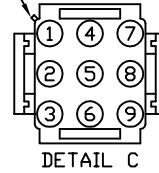

DETAIL C

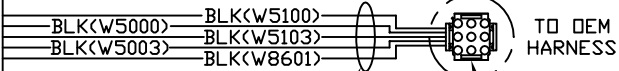

AP58578

PIN

- 1. N/C
- 2. BLK<W5000> ROOM 1 EXTEND
- 3. BLK<W5100> ROOM 1 RETRACT
- 4. N/C
- 5. BLK<W5003> ROOM 4 EXTEND
- 6. BLK<W5103> ROOM 4 RETRACT
- 7. BLK<W8601> PUMP REQUEST
- 8. N/C
- 9. N/C

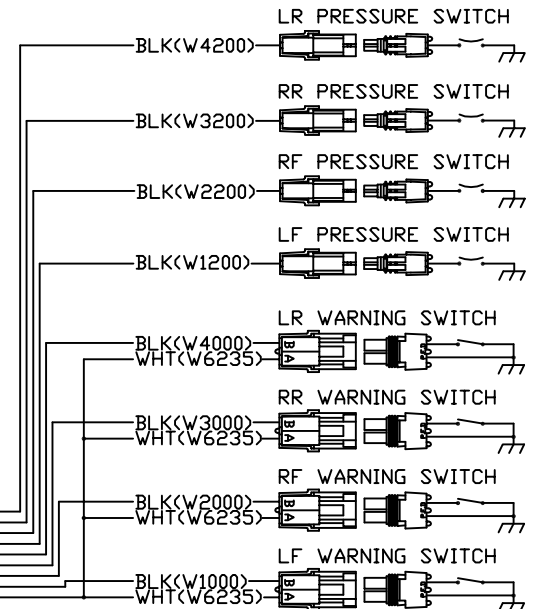

AP58568

NOTE: INSTALLATION MUST CONFORM TO GOOD SHOP PRACTICES, SAE STANDARDS, RVIA STANDARDS, AND OTHER APPLICABLE STANDARDS.

MP91361 D
09FEB18