

FRONT VIEW - AP58468

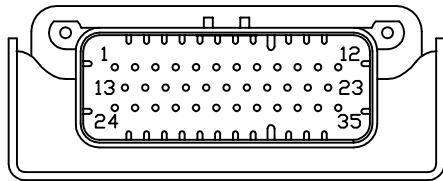

- PIN
1. BLK(W9000) - PARK BRAKE
  2. N/C
  3. BLK(W8101) - 50 LB. PRESSURE SWITCH
  4. BLK(W0100) - LEFT SIDE SENSE
  5. BLK(W0400) - REAR SENSE
  6. BLK(W3000) - RIGHT REAR JACK WARNING SWITCH
  7. BLK(W2200) - RIGHT FRONT JACK PRESSURE SWITCH
  8. N/C
  9. BLK(W8601) - PUMP REQUEST
  10. N/C
  11. WHT(W6235) - WARNING SWITCH GROUND
  12. N/C
  13. N/C
  14. N/C
  15. N/C
  16. BLK(W0300) - RIGHT SIDE SENSE
  17. BLK(W2000) - RIGHT FRONT JACK WARNING SWITCH
  18. BLK(W1200) - LEFT FRONT JACK PRESSURE SWITCH
  19. N/C
  20. WHT(W6230) - TOUCH PANEL GROUND
  21. CAN SHIELD
  22. YELLOW - CAN HIGH
  23. GREEN - CAN LOW
  24. N/C
  25. BLK(W4200) - LEFT REAR JACK PRESSURE SWITCH
  26. BLK(W8100) - 3000 LB. PRESSURE SWITCH
  27. BLK(W0200) - FRONT SENSE
  28. BLK(W1000) - LEFT FRONT JACK WARNING SWITCH
  29. BLK(W4000) - LEFT REAR JACK WARNING SWITCH
  30. BLK(W3200) - RIGHT REAR JACK PRESSURE SWITCH
  31. N/C
  32. WHT(W6231) - LEVEL SENSOR GROUND
  33. RED(W6121) - LEVEL SENSOR POWER
  34. RED(W6800) - TOUCH PANEL POWER
  35. RED(W6120) - ACCESSORY

NOTE: WIRE NUMBERS ON THIS SHEET ARE REFERENCED TO HARNESS PLUGS.

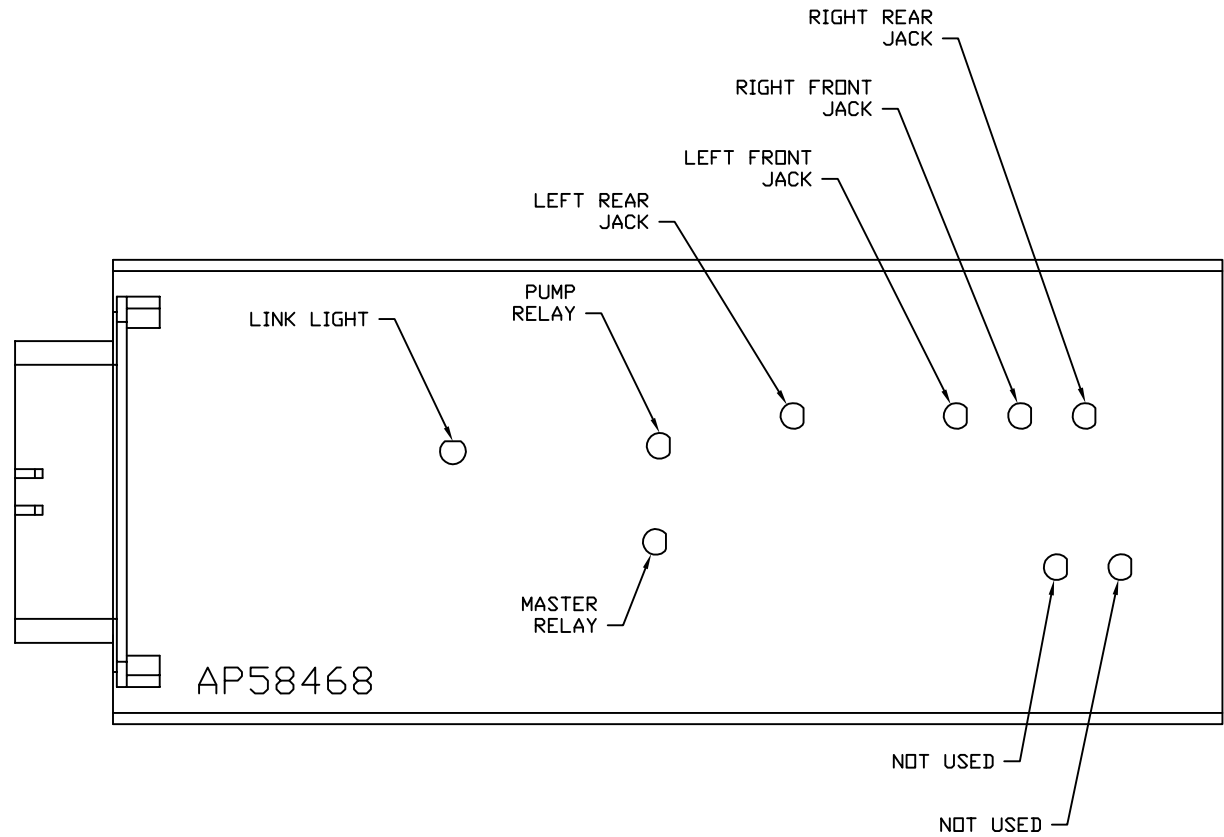

NOTE: INSTALLATION MUST CONFORM TO GOOD SHOP PRACTICES, SAE STANDARDS, RVIA STANDARDS, AND OTHER APPLICABLE STANDARDS.

		<b>HWH</b>		I-80 EXIT 267 SOUTH RT 1 MOSCOW, IOWA 52760	
		SCALE 1:3	DATE 08MAY19	DRAWN BY .	
		<b>SYSTEM SCHEMATIC ELEC</b>			
NO.	DATE	REVISION			
THE INFORMATION DISCLOSED ON THIS DRAWING IS CONFIDENTIAL AND MUST NOT BE DISCLOSED OR USED IN ANY MANNER WHICH WILL BE DETRIMENTAL TO THE HWH CORPORATION			DRAWING NUMBER MP91453 A/E		

PIN

1. BLK(W6810) SW. BATTERY FROM PUMP RELAY
2. BLK(W6800) SW. BATTERY FROM MASTER RELAY
3. BLK(W8601) PUMP (HAS DIODE)
4. WHT(W6230) GROUND

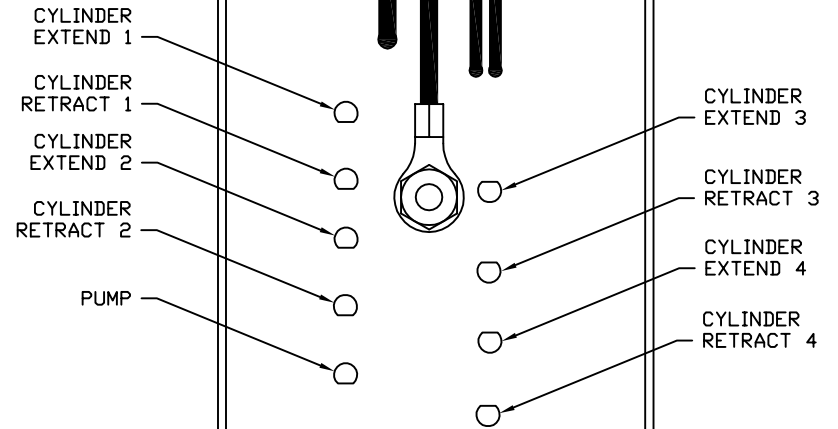
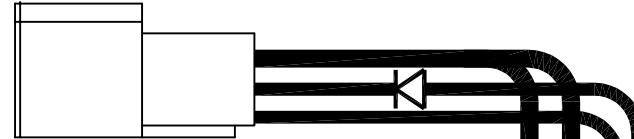
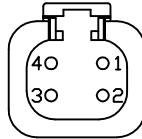

PIN

1. BLK(W5000) EXTEND ROOM 1
2. BLK(W5100) RETRACT ROOM 1
3. BLK(W5001) EXTEND ROOM 2
4. BLK(W5101) RETRACT ROOM 2
5. N/C
6. N/C
7. RED(W6805) +12V TO ROOM SWITCHES
8. N/C
9. BLK(W5002) EXTEND STEP
10. BLK(W5102) RETRACT STEP
11. BLK(W5003) EXTEND ROOM 3
12. BLK(W5103) RETRACT ROOM 3

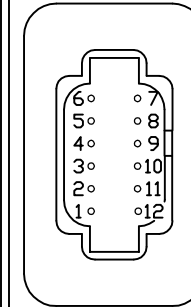

AP53292

NOTE: INSTALLATION MUST CONFORM TO GOOD SHOP PRACTICES, SAE STANDARDS, RVIA STANDARDS, AND OTHER APPLICABLE STANDARDS.

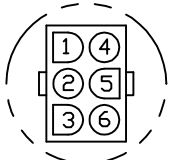

DETAIL A

- PIN  
 1. N/C  
 2. N/C  
 3. N/C  
 4. N/C  
 5. BLK(W7699) WARNING LED/ALARM CONTROL  
 6. N/C

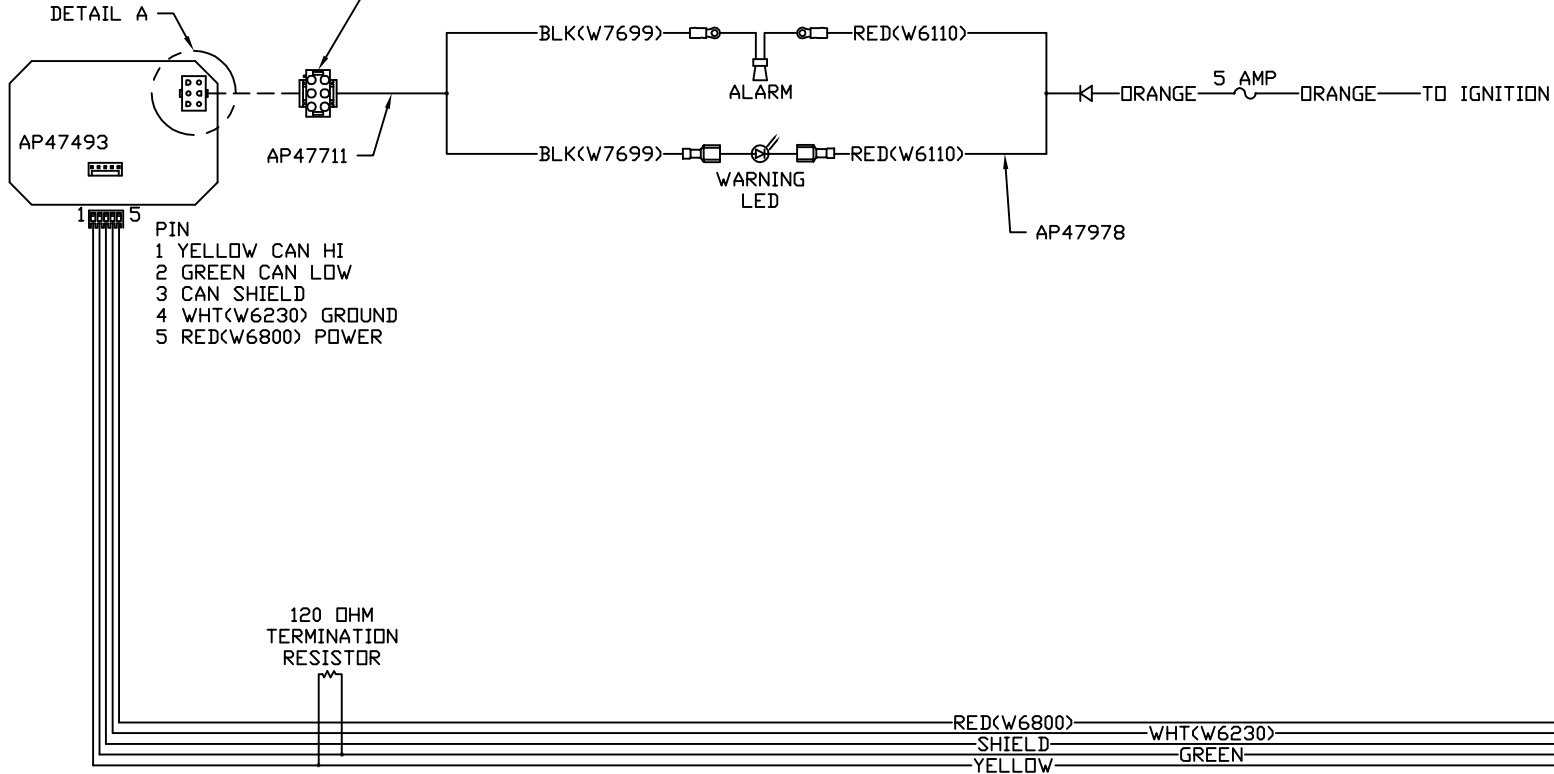

NOTE: INSTALLATION MUST CONFORM TO GOOD SHOP PRACTICES, SAE STANDARDS, RVIA STANDARDS, AND OTHER APPLICABLE STANDARDS.

RED(W6800)  
 SHIELD  
 YELLOW  
 WHT(W6230)  
 GREEN

AP59552

MP91453 C  
 08MAY19

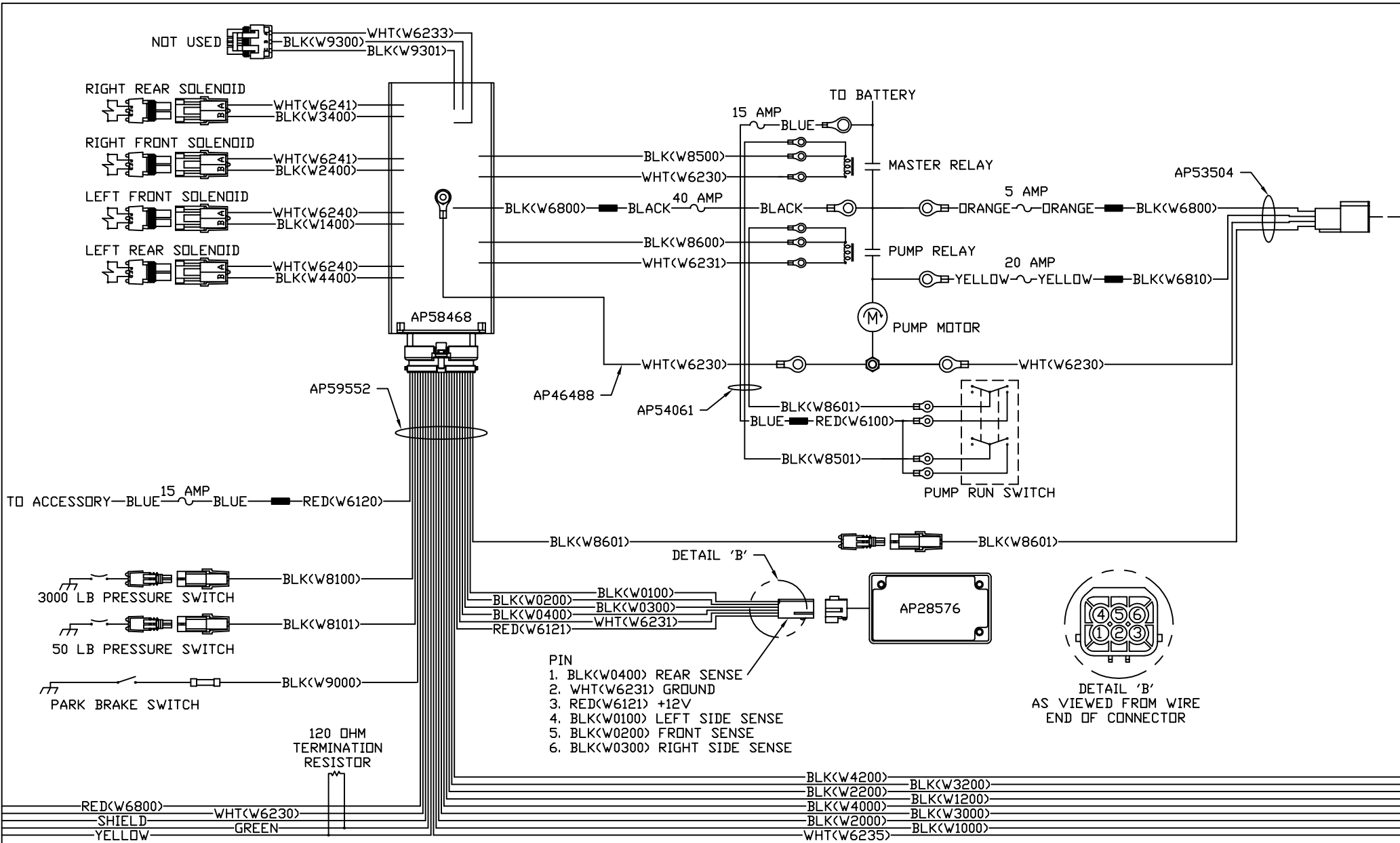

NOTE: INSTALLATION MUST CONFORM TO GOOD SHOP PRACTICES, SAE STANDARDS, RVIA STANDARDS, AND OTHER APPLICABLE STANDARDS.

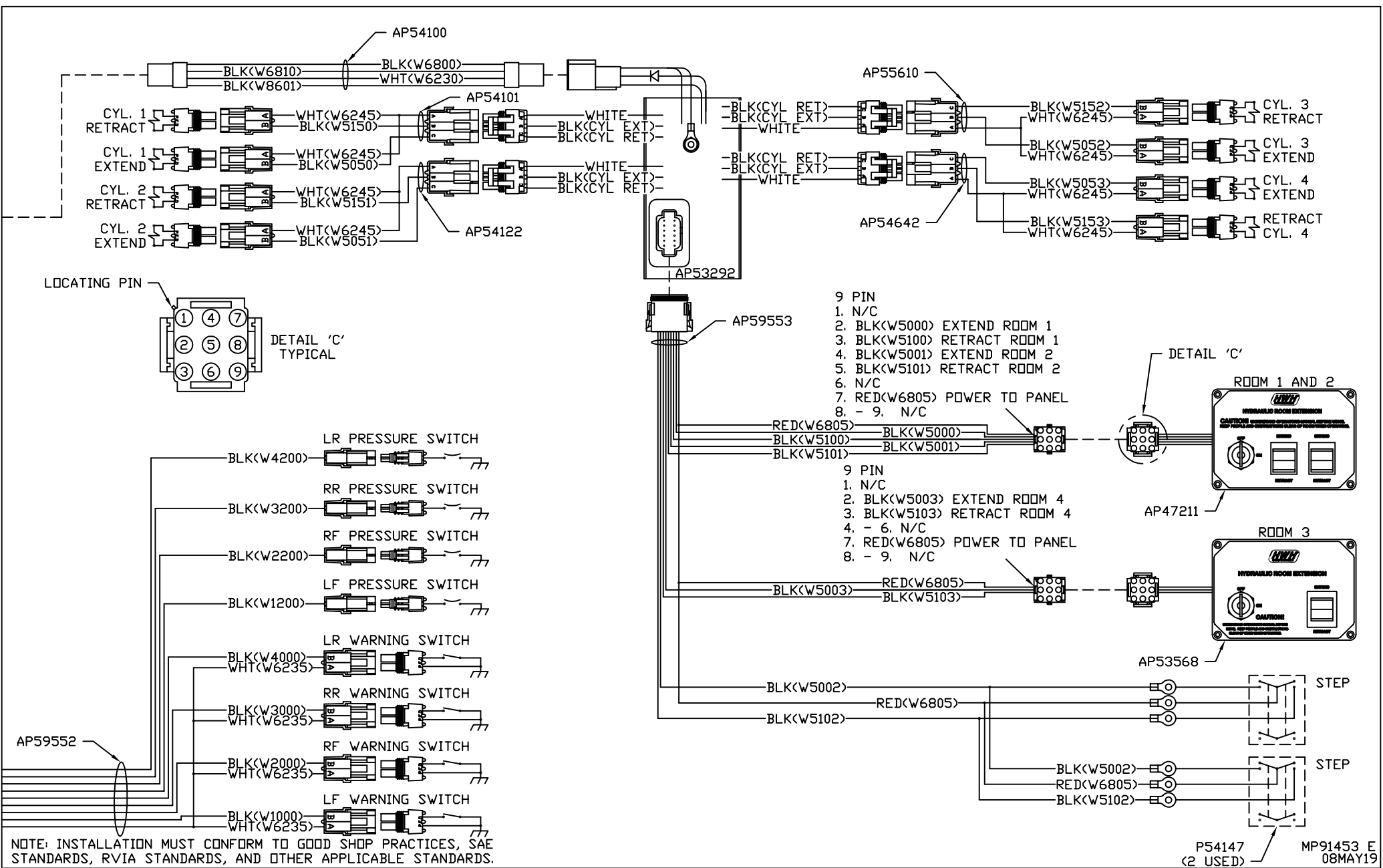

NOTE: INSTALLATION MUST CONFORM TO GOOD SHOP PRACTICES, SAE STANDARDS, RVIA STANDARDS, AND OTHER APPLICABLE STANDARDS.